

## Horizontal Die Grinders (Collet Output)

### 400GH Series

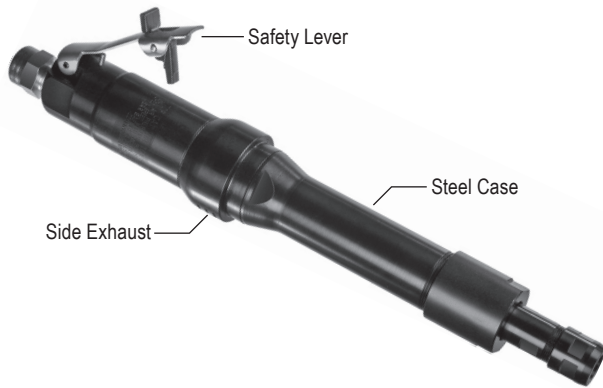

400GHKSD;20000;1/4

### 507H Series

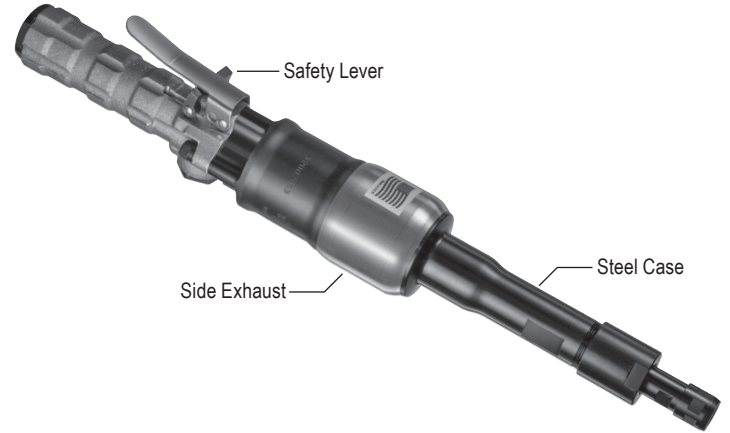

507HKSD;18000;1/4

Collet Type/Capacity	Exhaust Direction	Rated Speed	Lever Style	MODEL NUMBER	Collet Type/Capacity	Exhaust Direction	Rated Speed	Lever Style	MODEL NUMBER
1/4 Inch Standard ER Style Insert Collet 3/8 Inch or (10mm) Maximum	Side	20000 RPM	Standard Lever	400GHSD;20000;1/4	1/4 Inch Standard 3/8 Inch or (10 mm) Maximum	Side	18000 RPM	Standard Lever	507HLSD;18000;1/4
			Safety Lever	400GHKSD;20000;1/4					Safety Lever
	Rear		Standard Lever	400GHSRD;20000;1/4				Standard Lever	400GHKSRD;20000;1/4
			Safety Lever	400GHKSRD;20000;1/4					
	Side	18000 RPM	Standard Lever	400GHSD;18000;1/4				Standard Lever	400GHKSD;18000;1/4
			Safety Lever	400GHKSD;18000;1/4					
Rear	18000 RPM	Standard Lever	400GHSRD;18000;1/4	Standard Lever	400GHKSRD;18000;1/4				
		Safety Lever	400GHKSRD;18000;1/4						

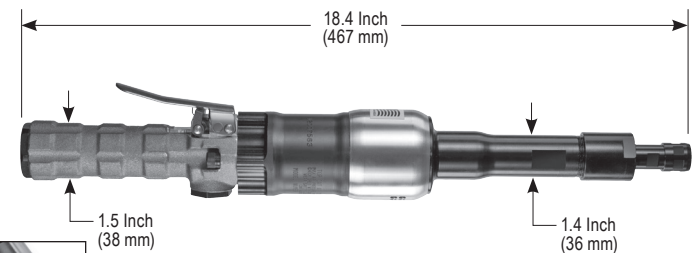
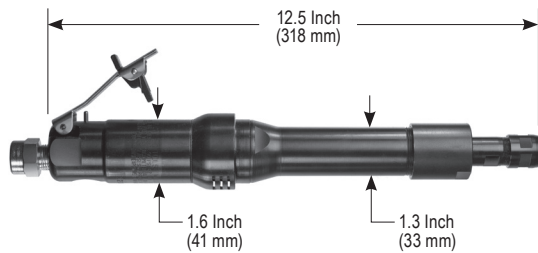

Insert Style or 2 Pc. Collets are available.

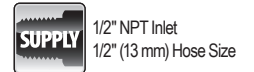
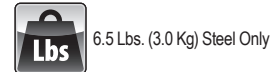
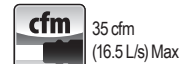
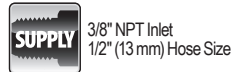
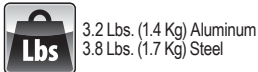
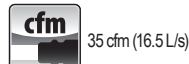

HORIZONTAL GRINDERS

### STANDARD EQUIPMENT

- Tool
- Operating Instructions and Service Manual
- Wrenches (sizes based on options)

### 400GH Series Alternate Options



### 507H Series Alternate Options Handles



### Inserted Tool Mounting

